



# Triple Power Lithium-ion Battery

50Ah

**User Manual**

Version 11.0

[www.solaxpower.com](http://www.solaxpower.com)

**SolaX Power Network Technology (Zhejiang) Co., Ltd.**

Add.: No. 288, Shizhu Road, Tonglu Economic Development Zone,  
Tonglu City, Zhejiang Province, 310000 P. R. CHINA  
Tel.: +86 (0) 571 5626 0011  
E-mail: [info@solaxpower.com](mailto:info@solaxpower.com)



320101004911



eManual in the QR code or at  
<http://kb.solaxpower.com/>

# CHANGE HISTORY

Changes between document versions are cumulative. The latest version contains all updates made in previous versions.

## **Version 11 (Oct. 31, 2023)**

- Updated 4.4.3 Accessories (added a note)
- Changed the machine drawing, and changed the brand of terminal

## **Version 10 (Aug. 31, 2023)**

- Updated 2.1.2 Explanation of Symbols (deleted a caution)
- Updated 3.3 Specification (changed the storage temperature range & model)
- Updated 8 Maintenance (changed the storage temperature range)

## **Version 09 (Nov. 23, 2022)**

- Modified IP rate, certification icon
- Added a "Note"

## **Version 08 (Sep. 9, 2022)**

- Modified TUV ICON
- Modified CAN into BMS

## **Version 07 (Jun. 8, 2022)**

- Added ukca icon, and waterproof cap in the figures
- Added a method of floor mounting

## **Version 06 (May 18, 2021)**

- Added a supplementary note about battery SOC

## **Version 05 (May 11, 2021)**

- Added Chapter 8

## **Version 02 (Nov. 7, 2019)**

- Change appearance drawing
- Added Ground Nut
- Delete the black surface of the s1 and s2 indicator lights

## **Version 01 (Jun. 4, 2019)**

- Delete one terminal on both the positive and negative power cables)

## **Version 00 (Apr. 26, 2019)**

- Initial release

# CONTENTS

<b>1</b>	<b>NOTE ON THIS MANUAL</b> .....	1
1.1	SCOPE OF VALIDITY.....	1
1.2	TARGET GROUP.....	1
1.3	SYMBOLS USED.....	1
<b>2</b>	<b>SAFETY</b> .....	2
2.1	SAFETY INSTRUCTIONS.....	2
2.1.1	GENERAL SAFETY PRECAUTIONS.....	2
2.1.2	EXPLANATION OF SYMBOLS.....	3
2.2	RESPONSE TO EMERGENCY SITUATIONS.....	5
2.2.1	LEAKING BATTERIES.....	5
2.2.2	FIRE.....	5
2.2.3	WET BATTERIES AND DAMAGED BATTERIES.....	5
2.3	QUALIFIED INSTALLER.....	6
<b>3</b>	<b>PRODUCT INTRODUCTION</b> .....	7
3.1	PRODUCT OVERVIEW.....	7
3.1.1	DIMENSION AND WEIGHT.....	7
3.1.2	APPEARANCE.....	8
3.2	BASIC FEATURES.....	10
3.2.1	FEATURES.....	10
3.2.2	CERTIFICATIONS.....	10
3.3	SPECIFICATIONS.....	11
3.3.1	T-BAT SYS-HV CONFIGURATION LIST.....	11
3.3.2	PERFORMANCE.....	11
<b>4</b>	<b>INSTALLATION</b> .....	12
4.1	INSTALLATION PREREQUISITES.....	12
4.2	SAFETY GEAR.....	12
4.3	TOOLS.....	13
4.4	INSTALLATION.....	13
4.4.1	CHECK FOR TRANSPORT DAMAGE.....	13
4.4.2	UNPACKING.....	13
4.4.3	ACCESSORIES.....	14
4.4.4	BATTERY INSTALLATION STEPS.....	16
4.5	<b>CABLE CONNECTION</b> .....	20
4.5.1	CONNECTING POWER CABLES BETWEEN BATTERY PACKS.....	20
4.5.2	CONNECTING POWER CABLES TO INVERTER.....	22
4.5.3	CONNECTING BMS COMMUNICATION CABLE.....	26
4.5.4	CONNECTING RS485 COMMUNICATION CABLE.....	27
4.5.5	CONNECTING GROUND WIRE.....	28
4.5.6	OVERALL INSTALLATION.....	29
4.6	OVERVIEW OF INSTALLATION.....	31
<b>5</b>	<b>COMMISSIONING</b> .....	32
5.1	CONFIGURING BATTERY SYSTEM.....	32
5.2	COMMISSIONING.....	33
5.3	STATUS INDICATORS.....	35
5.3.1	BMS .....	35
5.3.2	BATTERY PACK.....	36
5.4	SHUTTING DOWN T-BAT SYSTEM.....	36
<b>6</b>	<b>TROUBLESHOOTING</b> .....	37
6.1	TROUBLESHOOTING.....	37
<b>7</b>	<b>DECOMMISSIONING</b> .....	40
7.1	DISMANTLING THE BATTERY.....	40
7.2	PACKAGING.....	40
<b>8</b>	<b>MAINTENANCE</b> .....	41
<b>9</b>	<b>DISCLAIMER</b> .....	42
*	<b>WARRANTY REGISTRATION FORM</b>	

## 1 Note on this Manual

### 1.1 Scope of Validity

This manual is an integral part of T-BAT Series. It describes the assembly, installation, commissioning, maintenance and failure of the product. Please read it carefully before operating.

T-BAT SYS-HV

---

T-BAT H 5.8 / T-BAT H 5.8 V2

---

T-BAT PACK-HV

---

HV11550 / HV11550 V2

---

NOTE: There are 4 models for T-BAT system, including BMS and battery packs. Please refer to section 3.3.1 T-BAT SYS HV Configuration List on page 11 for more information.

### 1.2 Target Group

This manual is for qualified electricians. The tasks described in this manual may only be performed by qualified electricians.

### 1.3 Symbols Used



**DANGER!**

"DANGER" indicates a hazardous situation which, if not avoided, will result in death or serious injury.



**WARNING!**

"WARNING" indicates a hazardous situation which, if not avoided, could result in death or serious injury.



**CAUTION!**

"CAUTION" indicates a hazardous situation which, if not avoided, could result in minor or moderate injury.



**NOTE!**

"NOTE" provides tips that are valuable for the optimal operation of your product.



## 2 Safety

### 2.1 Safety Instructions

For safety reasons, installers are responsible for familiarizing themselves with the contents of this manual and all warnings before performing installation.

#### 2.1.1 General Safety Precautions

**⚠ WARNING!**

Please don't crush or impact the battery, and always dispose it according to the safety regulation.

Observe the following precautions:



- Risks of explosion
- Do not subject the battery to strong impacts.
- Do not crush or puncture the battery.
- Do not dispose of the battery in a fire.
- Risks of fire
- Do not expose the battery to temperatures in excess of 55°C.
- Do not place the battery near a heat source, such as a fireplace.
- Do not expose the battery to direct sunlight.
- Do not allow the battery connectors to touch conductive objects such as wires.
- Risks of electric shock
- Do not disassemble the battery.
- Do not touch the battery with wet hands.
- Do not expose the battery to moisture or liquids.
- Keep the battery away from children and animals.
- Risks of damage to the battery
- Do not allow the battery to get in contact with liquids.
- Do not subject the battery to high pressures.
- Do not place any objects on top of the battery.





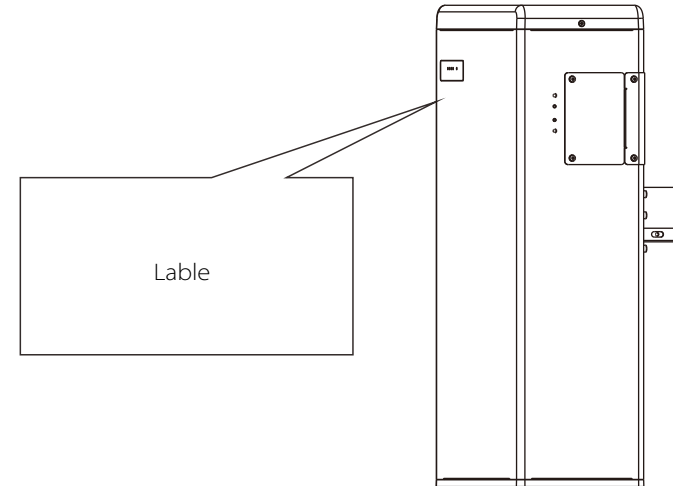

T-BAT SYS-HV can only be used in the household energy field. It is not allowed to be used in other industries, such as the medical equipment industry and automotive application industry.

### 2.1.2 Explanation of Symbols

This section gives an explanation of all the symbols shown on the T-BAT system and on the warning label.



Symbol	Explanation
	The inverter complies with the requirements of the applicable CE guidelines
	The inverter complies with the requirements of the applicable CSA guidelines
	The battery system should not be disposed together with the household waste. Disposal information can be found in the enclosed documentation.

	TUV mark for IEC62619
	The battery system should be disposed of at a proper facility for environmentally safe recycling.
	The battery system should not be disposed together with the household waste. Disposal information can be found in the enclosed documentation.
	Wear protective glasses
	Observe enclosed documentation.
	Keep the battery system away from open flames or ignition sources.
	Keep the battery system away from children.
	Danger of high voltages. Danger to life due to high voltages in the battery system!
	Danger. Risk of electric shock!
	The battery pack may explode.

## 2.2 Response to Emergency Situations

### 2.2.1 Leaking Batteries

If the battery leaks electrolyte which is corrosive, avoid contact with the leaking liquid or gas. Direct contact may lead to skin irritation or chemical burns. If one is exposed to the leaked substance, do these actions:

Accidental inhalation of harmful substances: Evacuate people from the contaminated area, and seek medical attention immediately.

Eye contact: Rinse eyes with flowing water for 15 minutes, and seek medical attention immediately.

Dermal contact: Wash the affected area thoroughly with soap and water, and seek medical attention immediately.

Ingestion: Induce vomiting, and seek medical attention immediately.

### 2.2.2 Fire

Please keep a Class ABC fire extinguisher or a carbon dioxide extinguisher near the equipment.



**WARNING!**

The battery pack may catch fire when heated above 150°C.

If a fire breaks out at where the battery is installed, do these actions:

1. Extinguish the fire before the battery catches fire;
2. If the battery has caught fire, do not try to extinguish the fire. Evacuate people immediately.

**WARNING!**

If the battery catches fire, it will produce noxious and poisonous gases. Do not approach.

### 2.2.3 Wet Batteries and Damaged Batteries

If the battery is wet or submerged in water, do not try to access it.

If the battery seems to be damaged, they are not fit for use and may pose a danger to people or property.

Please pack the battery in its original container, and then return it to our company or your distributor.

**CAUTION!**

Damaged batteries may leak electrolyte or produce flammable gas. If you suspect such damage, immediately contact our company for advice and support.

## 2.3 Qualified Installer

### ⚠ WARNING!

All operations of T-BAT SYS-HV relating to electrical connection and installation must be carried out by qualified personnel.

A skilled worker is defined as a trained and qualified electrician or installer who has all of the following skills and experience:

- Knowledge of the functional principles and operation of on-grid systems;
- Knowledge of dangers and risks associated with installing and using electrical devices and acceptable mitigation methods;
- Knowledge of the installation of electrical devices;
- Knowledge of and adherence to this Manual and all safety precautions and best practices;

## 3 Product Introduction

### 3.1 Product Overview

#### 3.1.1 Demension and Weight

A battery management system (BMS) is an electronic system that manages a rechargeable battery.

Battery is a type of electrical battery which can be charged, discharged into a load.

A battery system includes a BMS and battery pack(s).

### 👉 NOTE!

There are two generations of the device: the V1 and V2. All the drawings attached to the User Manual are the model of the second generation.

	T-BAT H 5.8 T-BAT H 5.8 V2	HV11550 HV11550 V2
Length	474mm	474mm
Width	193mm	193mm
Height	708mm	647mm
Weight	72.2kg	68.5kg

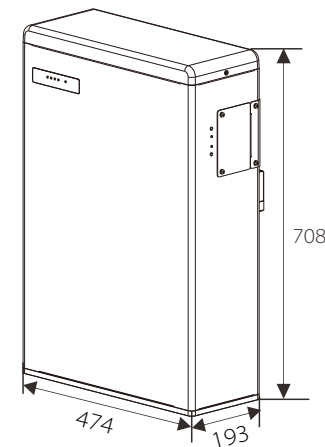

T-BAT H 5.8  
T-BAT H 5.8 V2

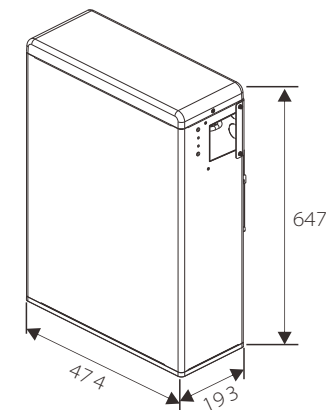

HV11550  
HV11550 V2  
(Battery Pack)

3.1.2 Appearance

- Section view of T-BAT H 5.8 / T-BAT H 5.8 V2

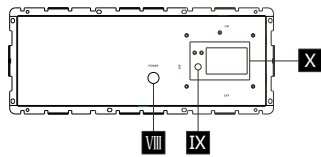
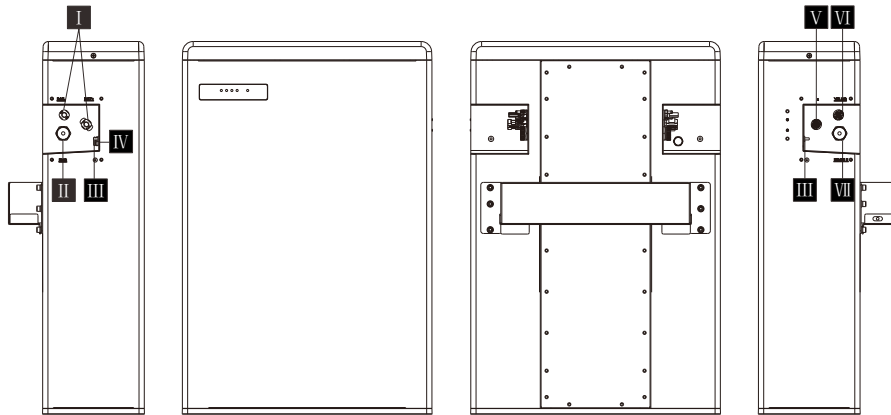

Object	Mark	Description
I	BAT+/BAT-	Charge/Discharge Connectors
II	BMS	BMS Connector
III	GND	GND
IV	/	Air Valve
V	-	Power Connector to + of next battery pack, or to YPLUG of the same pack
VI	YPLUG	Power Connector' to XPLUG of next battery pack, or to "- of the same pack
VII	RS485 II	RS485 Connector to RS485 I of next battery pack
VIII	POWER	Power Button
IX	DIP	DIP Switch
X	ON/OFF	Circuit Breaker

- Section view of HV11550 / HV11550 V2

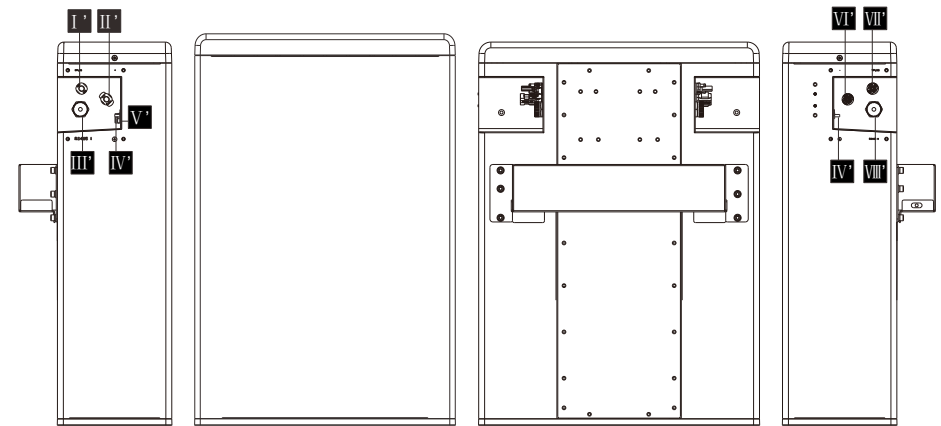

Object	Mark	Description
I'	XPLUG	Power Connector' to YPLUG of upper battery pack
II'	+	Power Connector to "+ of upper battery pack
III'	RS485 I	RS485 Connector to RS485 II of upper battery pack
IV'	GND	GND
V'	/	Air valve
VI'	-	Power Connector to + of next battery pack, or to YPLUG of the same pack
VII'	YPLUG	Power Connector' to XPLUG of next battery pack, or to "- of the same pack
VIII'	RS485 II	Rs485 Connector to RS485 I of next battery pack

## 3.2 Basic Features

### 3.2.1 Features

The T-BAT SYS-HV is one of the advanced energy storage systems on the market today, incorporating state-of-the-art technology, high reliability, and convenient control features shown as below:

- 90% DOD
- 99% faradic charge efficiency
- 95% battery roundtrip efficiency
- Cycle life > 6000 times
- Secondary protection by hardware
- IP65 protection level
- Safety & reliability
- Small footprint
- Floor or wall mounting

### 3.2.2 Certifications

T-BAT system safety	V1: CE, IEC 62619, UKCA, VDE2510 JET, UL1973, FCC V2: CE, IEC 62040, IEC 62619, UKCA, VDE2510, RoHS
Battery cell safety	UL 1642
UN number	UN 3480
Hazardous materials classification	Class 9
UN transportation testing requirements	UN 38.3
Ingress Protection	IP65

## 3.3 Specifications

### 3.3.1 T-BAT SYS-HV Configuration List

No.	Model	Battery pack	Energy (kWh)	Voltage (V)
1	T-BAT H 5.8	T-BAT H 5.8*1	5.8	100-131
2	T-BAT H 11.5	T-BAT H 5.8*1 + HV11550*1	11.5	200-262
3	T-BAT H 17.3	T-BAT H 5.8*1 + HV11550*2	17.3	300-393
4	T-BAT H 23.0	T-BAT H 5.8*1 + HV11550*3	23.0	400-524
5	T-BAT H 5.8 V2	T-BAT H 5.8 V2*1	5.8	100-131
6	T-BAT H 11.5 V2	T-BAT H 5.8 V2*1 + HV11550 V2*1	11.5	200-262
7	T-BAT H 17.3 V2	T-BAT H 5.8 V2*1 + HV11550 V2*2	17.3	300-393
8	T-BAT H 23.0 V2	T-BAT H 5.8 V2*1 + HV11550 V2*3	23.0	400-524

### 3.3.2 Performance

	T-BAT H 5.8 T-BAT H 5.8 V2	HV11550 HV11550 V2
Dimension (mm)	474*193*708	474*193*647
Weight (kg)	72.2	68.5
Nominal Voltage (Vdc)	115.2	115.2
Operating Voltage (Vdc):	100-131	100-131
Nominal Capacity (Ah):	50	50
Max. charge/discharge Current (A) :	35	35
Recommend Charge/Discharge Current (A):	25	25
Standard Power (kW)	2.8	2.8
Maximum Power (kW)	4.0	4.0
Altitude (m)	≤ 2000	
Faradic Charge Efficiency (25°C/77°F)	99%	
Battery Roundtrip Efficiency (C/3, 25°C/77°F)	95%	
Expected Lifetime (25°C/77°F)	10 years	
Cycle life (90% DOD, 25°C/77°F)	6000 cycles	
Available Operating Temperature	0-55°C	
Full-load Operating Temperature	5-48°C	
Storage Temperature	-20~+30°C (12 months)	
	+30~+55°C (6 months)	
Relative Humidity [%]	4 to 100 (condensing)	
Ingress Protection	IP65	

## 4 Installation

### 4.1 Installation Prerequisites

Before installation, make sure that the installation site meets the following conditions:

- The building is designed with resistance to earthquakes;
- The location is far away from the sea, to avoid sea water and humid air;
- The floor shall be flat;
- There are no flammable or explosive materials nearby;
- The ambience shall be shady and cool, away from heat sources and direct sunlight;
- The temperature and humidity remain at a constant level;
- The installation site requires less dust and dirt;
- There are no corrosive gases, including ammonia and acid vapor; and
- The same generation products are recommended to give priority to use.

**NOTE!**

The Triple Power battery is rated at IP65. Thus, it can be installed outdoors as well as indoors. However, if the battery is installed outdoors, avoid direct exposure to the sun and humid air.

**NOTE!**

If the ambient temperature is beyond the operating range, the battery will stop operating to protect itself. The optimal temperature range for the battery to operate is from 15°C to 35°C. Frequent exposure to harsh temperatures may deteriorate the performance and lifetime of the battery.

**NOTE!**

**When installing the battery for the first time, the manufacturing date between battery modules should not exceed 3 months.**

### 4.2 Safety Gear

Installation and maintenance personnel must operate according to applicable federal, state and local regulations as well as the industry standard. The product installation personnel shall wear safety gears, etc. in order to avoid short circuit and personal injury.



Insulated Gloves



Safety Goggles



Safety Shoes

### 4.3 Tools

These tools are required to install the T-BAT system.

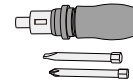

Torque Screwdriver



Phillips Screwdriver



Hexagon Wrench



Phillips Screwdriver



Slotted Screwdriver



Torque Wrench

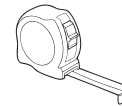

Tape Measure



Driller



Pencil or Marker

### 4.4 Installation

#### 4.4.1 Check for Transport Damage

Make sure the battery is intact during transportation. If there are any visible damages, such as cracks, please contact your dealer immediately.

#### 4.4.2 Unpacking

Unpack the battery package by removing the packing tape. Ensure the battery modules and relevant items are complete. See the package items on section 4.4.3 and check the packing list carefully. If any items are missing, immediately contact our company or your distributor.

**CAUTION!**

According to regional regulations, several people may be required for moving the equipment.

**WARNING!**

Please strictly follow the installation steps. The company will not assume any responsibility for any hurting or loss caused by improper assembling and operation.

4.4.3 Accessories

T-BAT H 5.8 / T-BAT H 5.8 V2:

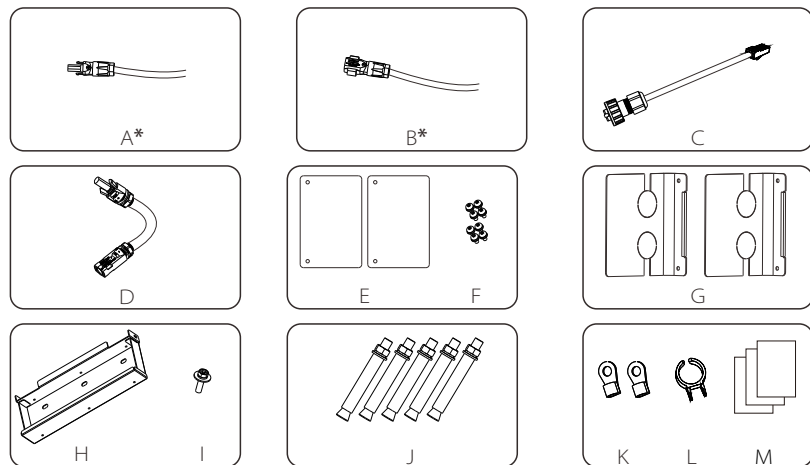

The table below lists the number of each component.

Object	Description	Quantity
A*	Power cable between inverter and T-BAT H 5.8/T-BAT H 5.8 V2 (+) (2 m)	1
B*	Power cable between inverter and T-BAT H 5.8/T-BAT H 5.8 V2 (-) (2 m)	1
C	BMS communication cable (2m)	1
D	Series-connected plug	1
E	Cover plate1	2
F	M4 screw	8
G	Cover plate2	2
H	Wall bracket	1
I	M5 screw	1
J	Expansion bolt	5
K	Ring terminal (for grounding)	2
L	Power cable disassembling tool	1
M	Documents	2

Note:

1. The above-mentioned accessories are only for one battery module. SolaX will provide corresponding accessories according to the number of battery modules.
2. The mark "\*" indicates that the connector on one end of the charging cable, connecting the battery and inverter, is delivered with the inverter's kit. And both the charging cables meet the requirements of B2ca.

HV11550 / HV11550 V2:

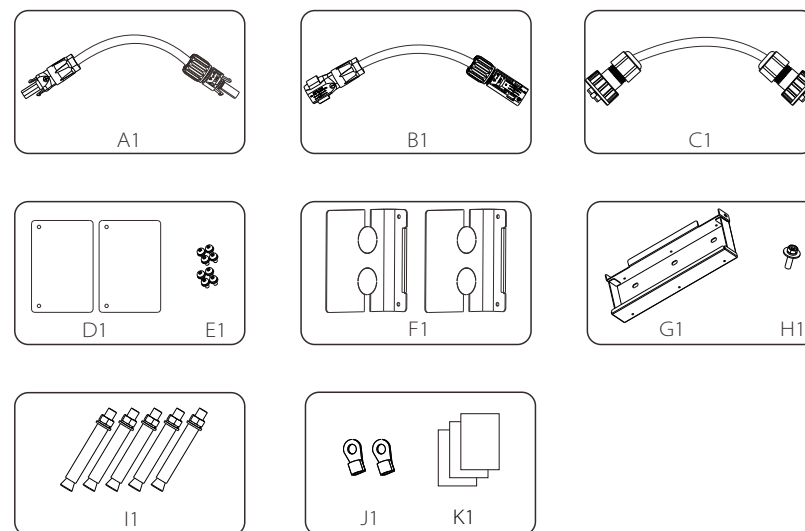

The table below lists the number of each component.

Object	Description	Quantity
A1	Power cable between battery packs (650 mm)	1
B1	Power cable' between battery packs (650 mm)	1
C1	RS485 communication cable (650 mm)	1
D1	Cover plate1	2
E1	M4 screw	8
F1	Cover plate2	2
G1	Wall bracket	1
H1	M5 screw	1
I1	Expansion bolt	5
J1	Ring terminal (for grounding)	2
K1	Document	1

4.4.4 Battery Installation Steps

There are two installation ways, wall mounting and floor mounting.

I. Wall mounting

It is recommended to keep a distance of 350 mm between two battery packs. Such a distance must be between 320 mm and 380 mm.

Steps (for T-BAT H 5.8 (T-BAT H 5.8 V2) or HV1 1550 (HV1 1550 V2)):

Make sure the wall is strong enough to withstand the weight of battery.

Step 1: Fix the wall bracket (H or G1) on the wall

- Use the wall bracket as a template to mark the position of the 5 holes;
- Drill holes with  $\phi 10$  driller, make sure the holes are deep enough (at least 50mm) for installing and tightening the expansion bolts (J or I1);
- Install the expansion bolts in the wall, and tighten the screws on the bracket by using the screw driller.

Step 2: Match the battery with the wall bracket

- Lift the battery to the wall bracket;
- Hang the battery over the wall bracket, move the battery close to the wall and match it on the wall bracket.

Step 3: Lock the joint between hanging board and wall bracket with M5 combinationscrew (I or H1).

Note: Keep the distance from installation point to the floor less than 650mm.

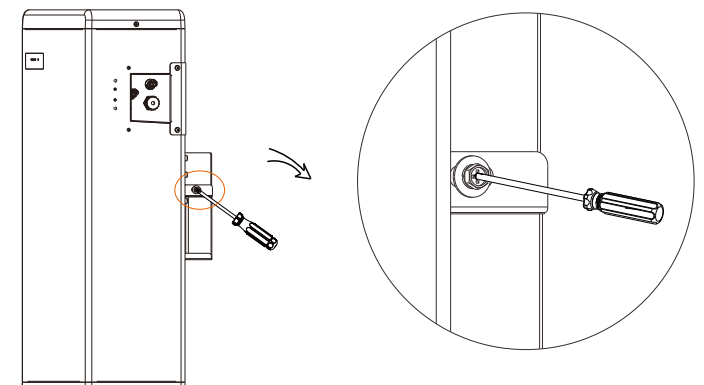
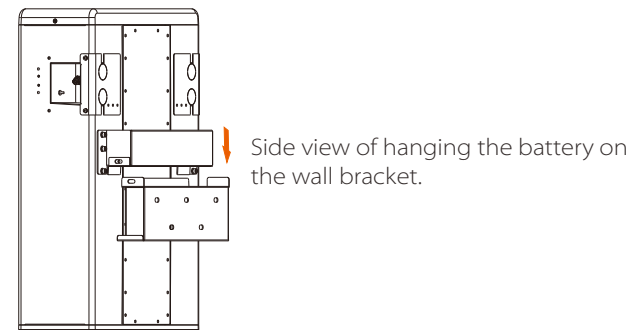
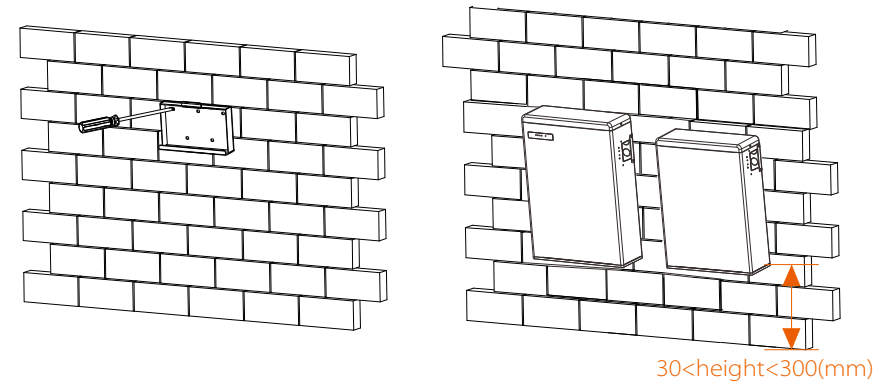
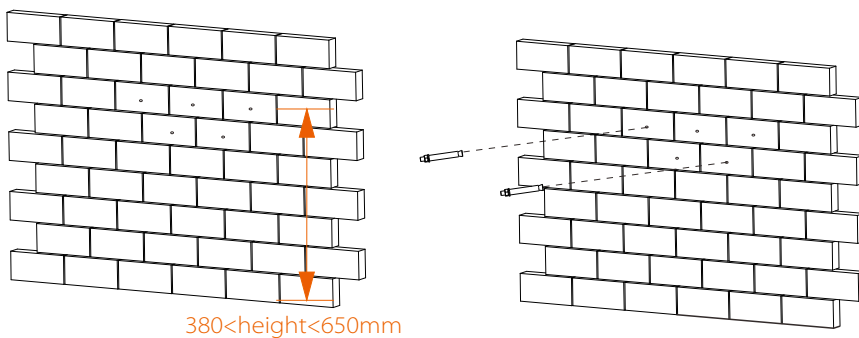



II. Floor mounting

Steps (for T-BAT H 5.8 (T-BAT H 5.8 V2) or HV11550 (HV11550 V2)), please refer to the steps for wall mounting on page 16.

Note: It is recommended to keep a distance of 350 mm between two battery packs. Such a distance must be between 320 mm and 380 mm.

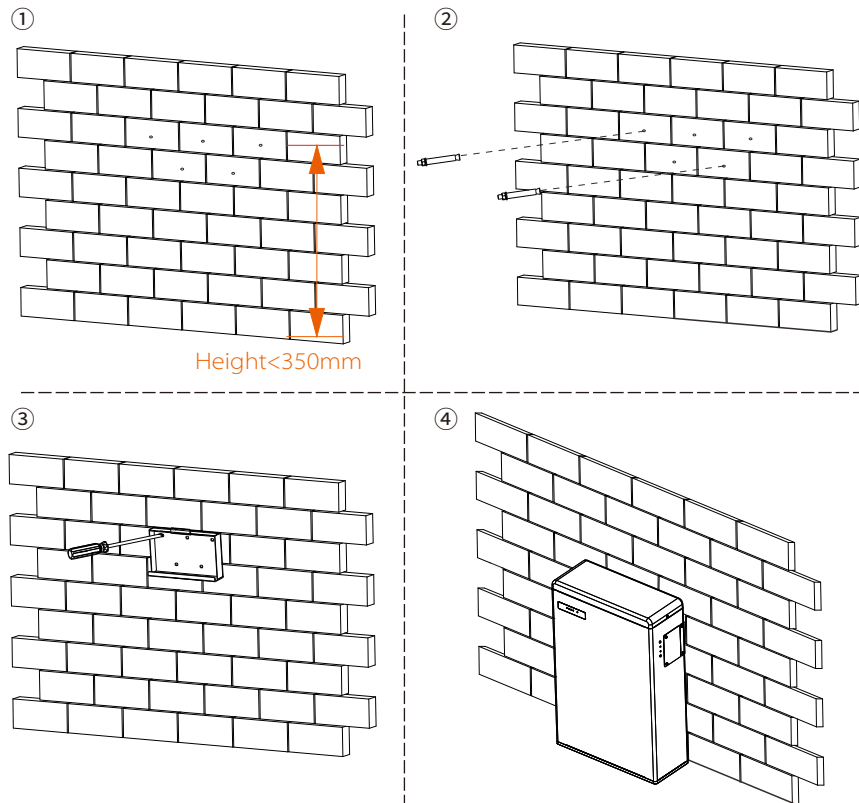

Note: To prevent the battery from becoming moist, it is recommended to place a foam cushion, or other cushion made up of other materials, with a height of 3 cm to 4 cm, under the battery.

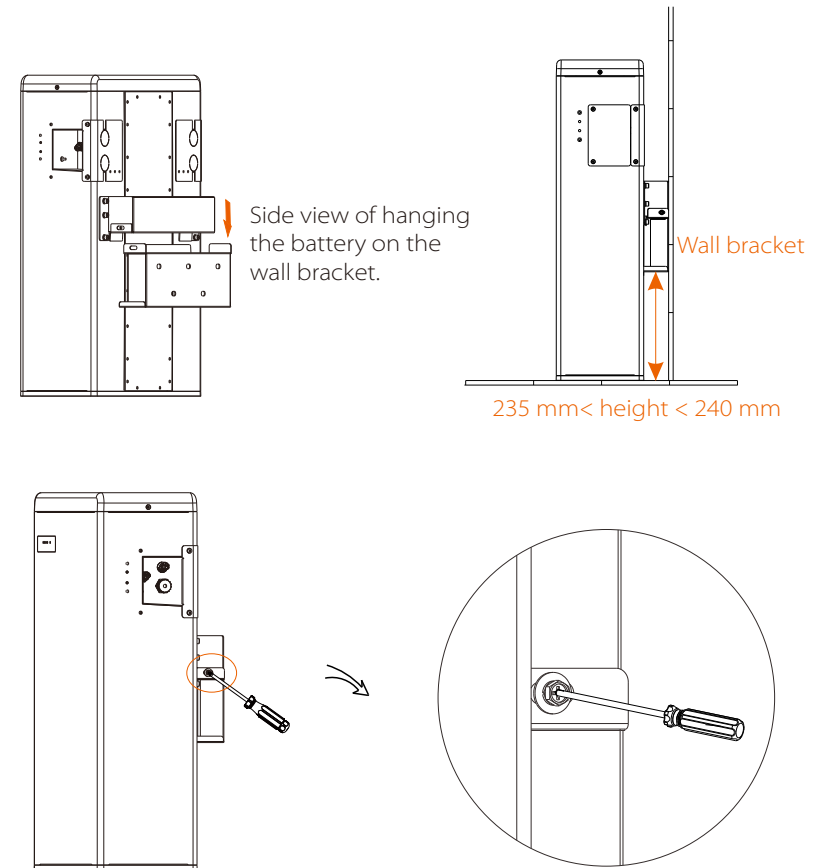

## 4.5 Cable Connection

### 4.5.1 Connecting Power Cables between Battery Packs

For T-BAT H 5.8 / T-BAT H 5.8 V2:

1. The only step of connecting power cable for T-BAT H 5.8/T-BAT H 5.8 V2 is connecting the series-connected cable to "-" and "YPLUG" on the right side. The series-connected cable is used to make a complete circuit.

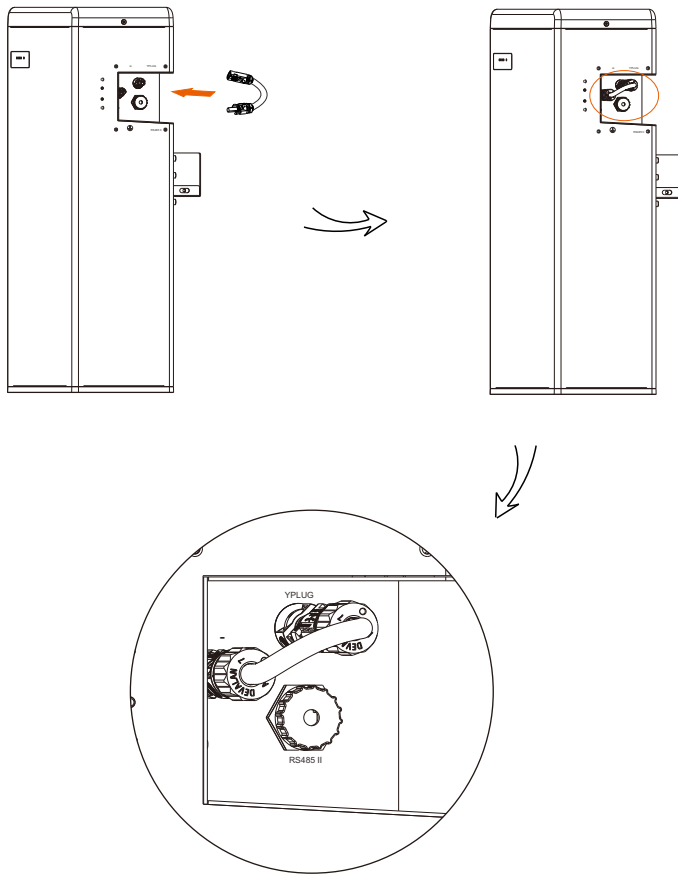

For T-BAT H 5.8/T-BAT H 5.8 V2 + 1~3 battery packs:

1. Connect "-" (V for T-BAT H 5.8 (T-BAT H 5.8 V2) or VI' for HV11550 (HV11550 V2)) on the right side to "+" (II) on the left side of the next battery pack.
2. Connect "YPLUG" (VI for T-BAT H 5.8 (T-BAT H 5.8 V2) or VII' for HV11550 (HV11550 V2)) on the right side to "XPLUG" (I) on the left side of the next battery pack.
3. The rest battery packs are connected in the same way.
4. Insert the series-connected cable at "-" and "YPLUG" on the right side of last battery pack to make a complete circuit.

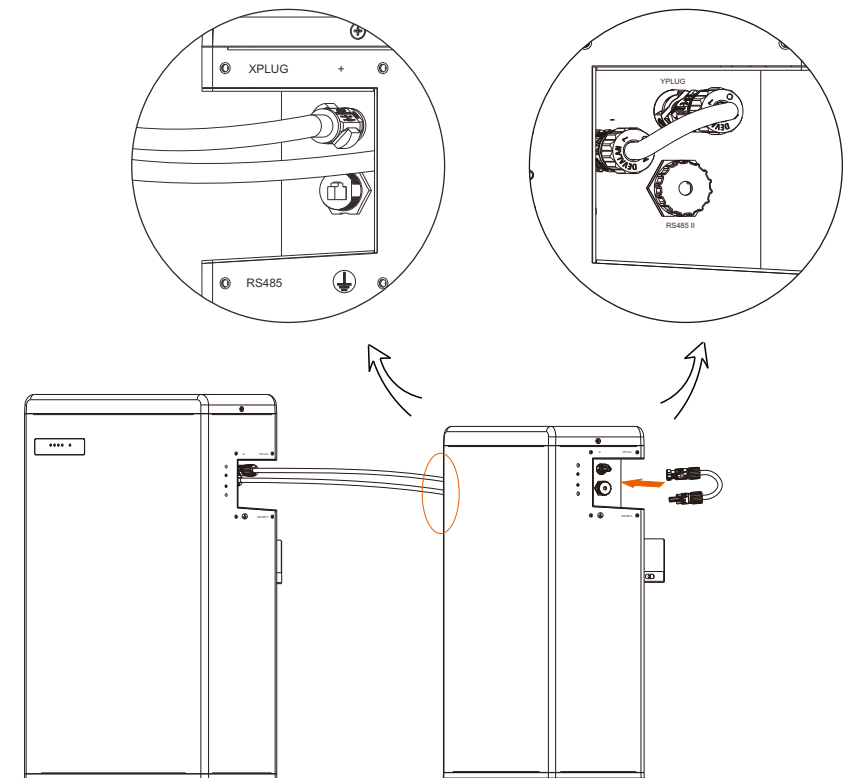

**Note!**  
Regardless of how many battery modules the user install, please put a waterproof cap on the unconnected communication port of the battery module.

4.5.2 Connecting Power Cables to Inverter

This step is going to connect power cables between inverter and T-BAT system. The default length of power cables are 2 meters, so customers can appropriately cut the cable according to the actual installation environment. As a result, each power cable has one terminal block when leaving the factory, and customers need to connect the other end of terminal block by themselves.

➤ Cable Connection Steps:

**NOTE!**  
In case the Phoenix terminal is equipped on both ports "-" and "YPlug" on the battery and inverter, respectively, please strictly follow the steps below to install Phoenix terminals on power cables.

- Step1. Strip the cable to 15mm.
- Step2. Insert the stripped cable up to the stop (negative cable for DC plug(-) and positive cable for DC socket(+) are live). Hold the housing on the screw connection.
- Step3. Press down the spring clamp until it clicks audibly into place (You should be able to see the fine wire strands in the chamber)
- Step4. Tighten the screw connection (tightening torque:  $2.0 \pm 0.2$  N·m)

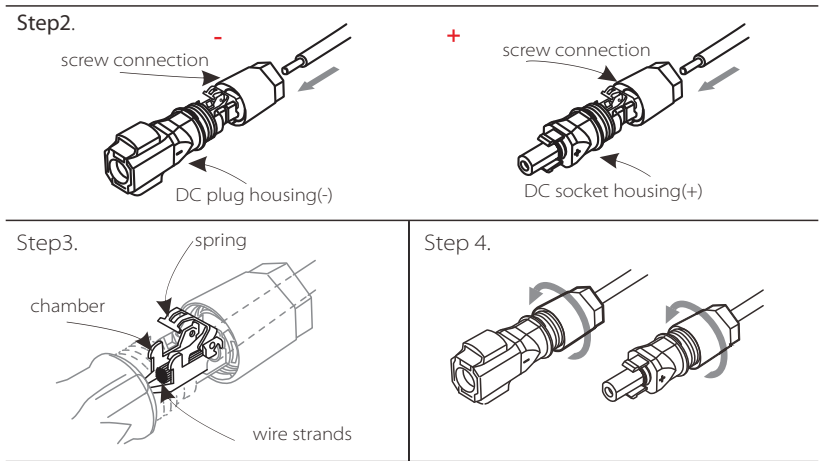

➤ Connecting Charging Cables between Inverter and T-BAT System:

1. Connect the the positive cable (+) (A) and negative cable (-) (B) to the BAT+ and BAT- respectively as shown in the following figure.

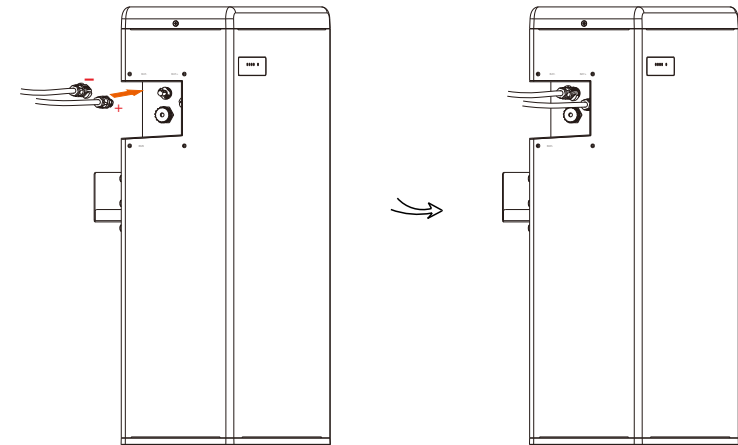

2. Keep the inverter off. Connect the other end of power cables (+,-) to the BAT (+, -) port on the inverter.

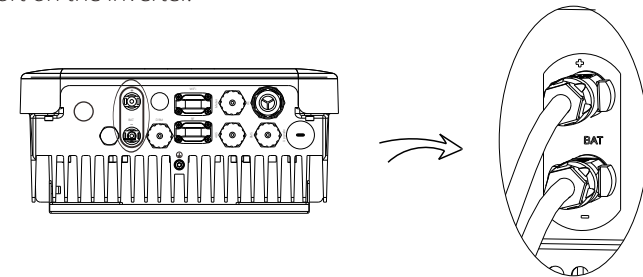

**NOTE!**

1. When connecting the cable to inverter, fit the two connectors together until the connection audibly locks into place.
2. Check to make sure the connection is securely locked.
3. Don't shake both ends of the cable at the joint once the connection is locked.

➤ Disassembling Power cable (on BAT+, BAT-, "+", XPLUG port)

Disassemble the power cable by plugging the slot type screwdriver or the Power cable disassemble tool(L) to the terminal groove of the power cable. Please see the illustration as shown below:

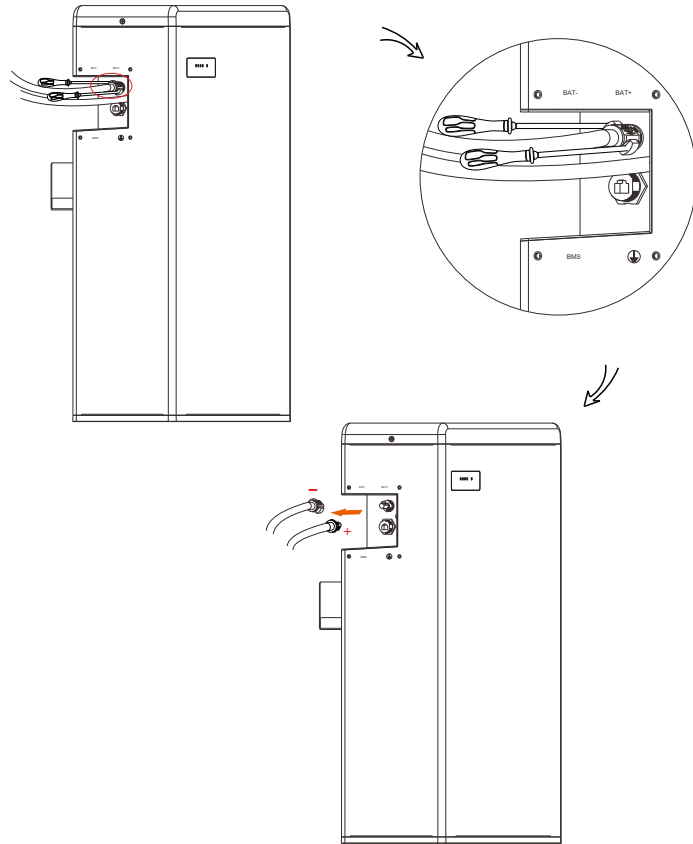

**⚠ CAUTION!**

DO NOT disassemble power cables when the T-BAT system is not turned off, otherwise there would be an arc discharge that could cause serious injury!

➤ Disassembling Power Cable (on "-", YPLUG port)

Disassemble the power line by plugging the Power cable disassembling tool (L) to the terminal groove of charging cable. Please see the illustration as shown below:

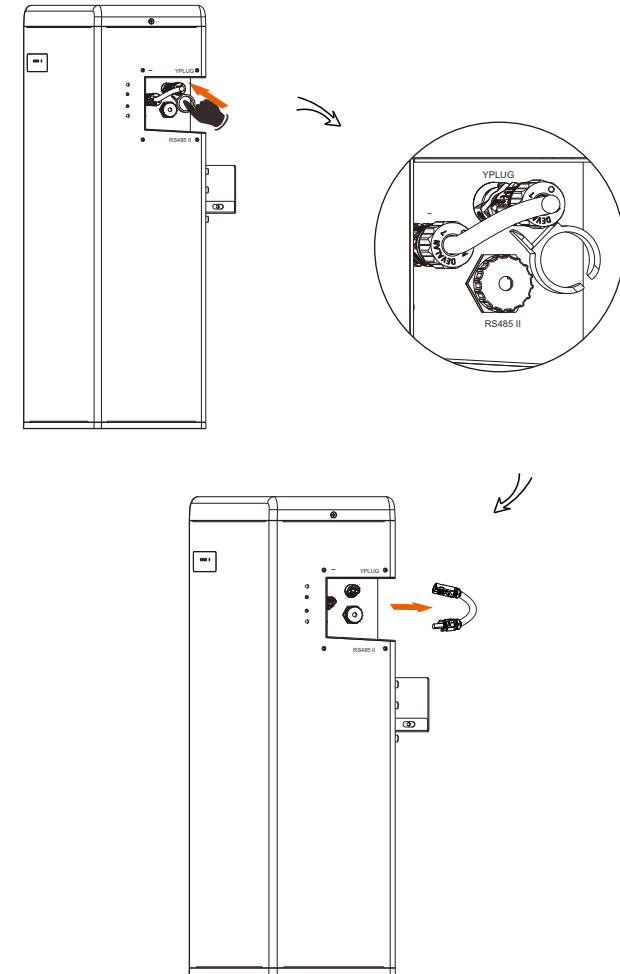

### 4.5.3 Connecting BMS Communication Cable

It is required for the BMS to communicate with the inverter for proper operation.

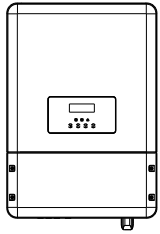

1. Insert one end of the BMS communication Cable (C) directly to the BMS port of inverter.

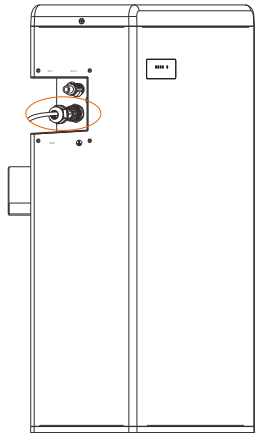

2. Insert the other end of the BMS communication Cable to the BMS connector (II) on the first battery pack which is marked in red. Assemble the cable gland and tighten the cable cap.

The wiring order of the communication cable is as follow:

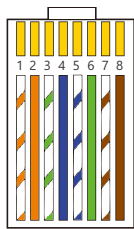
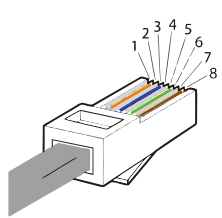

- 1) Orange stripes on white
- 2) Orange
- 3) Green stripes on white
- 4) Blue
- 5) Blue stripes on white
- 6) Green
- 7) Brown stripes on white
- 8) Brown

Sequence	1	2	3	4	5	6	7	8
BMS	/	GND	/	BMS_H	BMS_L	/	A1	B1

### 4.5.4 Connecting RS485 Communication Cable

For T-BAT H 5.8/T-BAT H 5.8 V2:

There's no need to use RS485 communication cable.

For T-BAT H 5.8/T-BAT H 5.8 V2 + 1~3 battery packs:

Connect RS485 II (VII for T-BAT H 5.8 (T-BAT H 5.8 V2) or VIII' for HV11550 (HV11550 V2)) of the first battery pack (as shown on the right) to RS485 I on the next battery pack (as shown on the left).

Assemble the cable gland and tighten the cable cap.

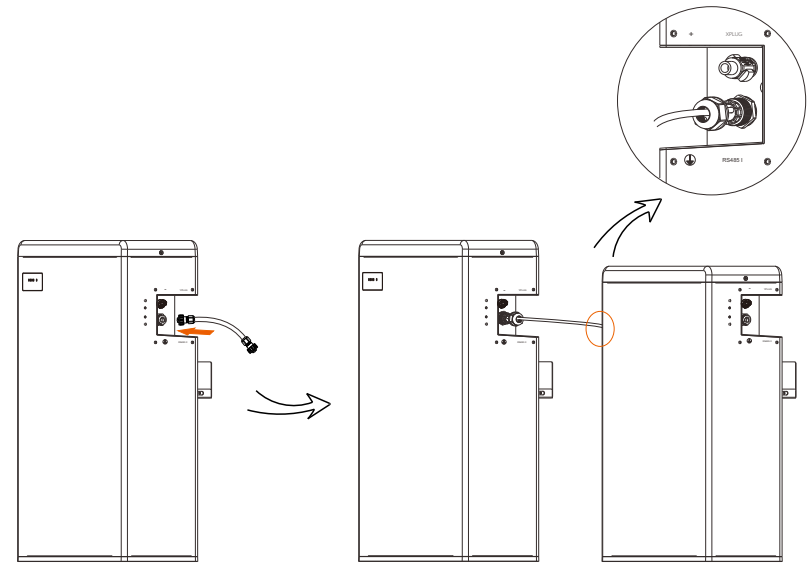

The wiring order of the communication cable is as follow:

Sequence	1	2	3	4	5	6	7	8
RS485I	VCC_485	GND_485	B2	N-	P+	A2	VCC_485_2	GND_485
RS485II	VCC_485	GND_485	B2	N-	P+	A2	VCC_485_2	GND_485

4.5.5 Connecting Ground Wire

The terminal point for GND connection is on the side of grooves as shown below:

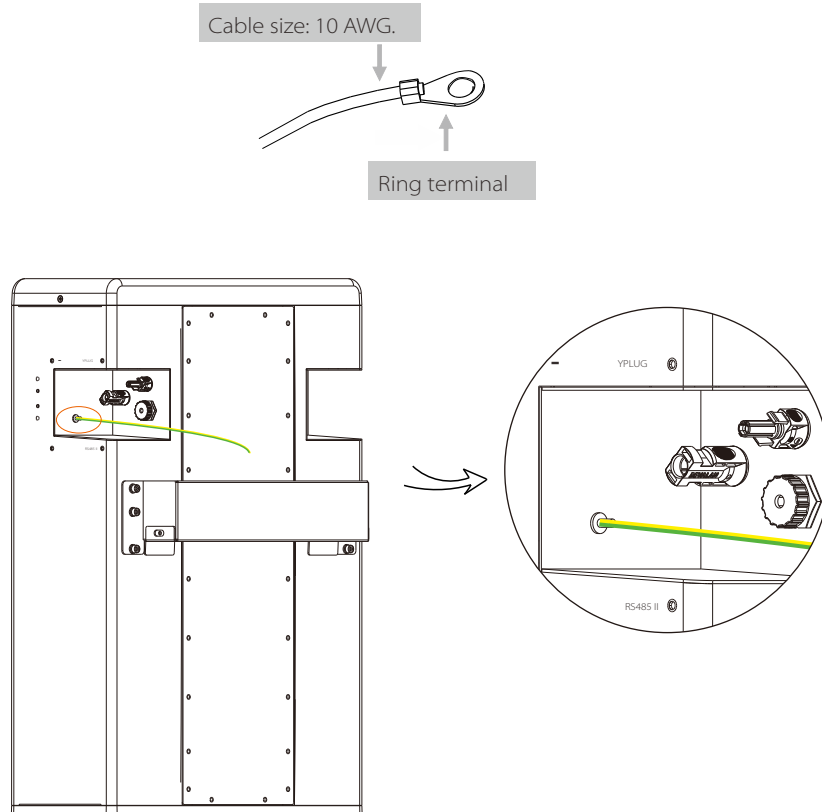

**CAUTION!**  
GND connection is mandatory!

4.5.6 Overall Installation

It is recommended to protect the cables with corrugated pipe.

For T-BAT H 5.8/T-BAT H 5.8 V2:

1. Connect all the cables on the left side of T-BAT H 5.8/T-BAT H 5.8 V2.
2. Run the cables through the corrugated pipe.
3. Do remember to insert the series-connected cable at "-" and "YPLUG" on the right side of the last battery pack to complete the internal circuit.
4. Set the cables into the groove of metal plates and screw them back to the battery pack on both sides.

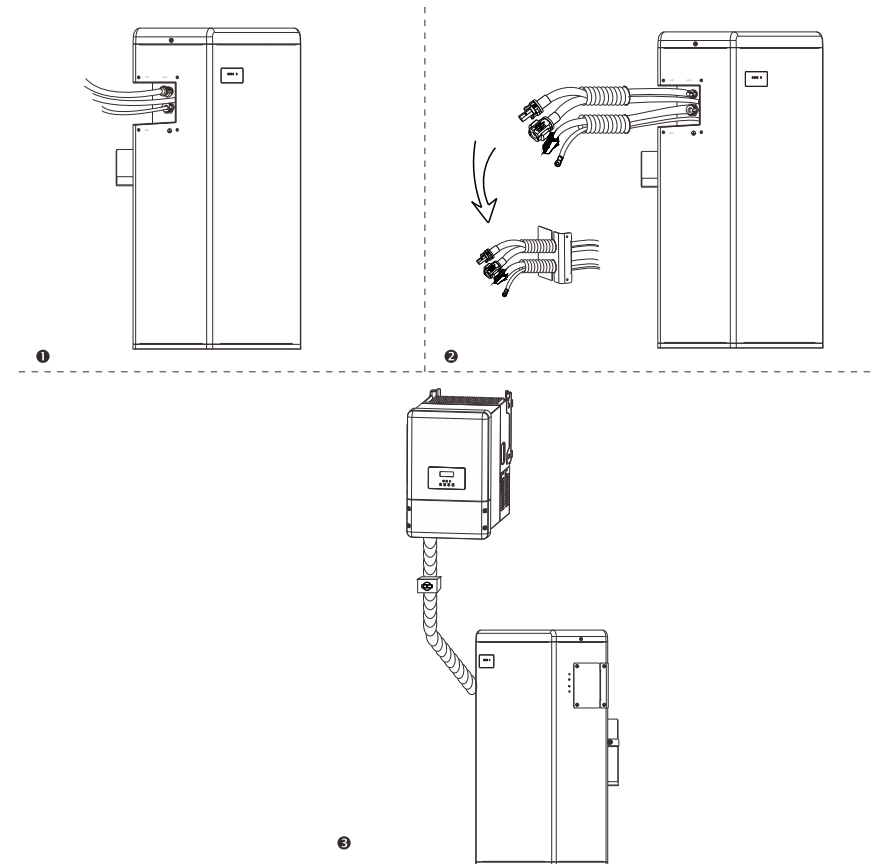

For T-BAT H 5.8/T-BAT H 5.8 V2 + 1~3 battery packs:

1. Connect the cables at one end of the T-BAT H 5.8/T-BAT H 5.8 V2 or HV11550/HV11550 V2.
2. Run the cables through the corrugated pipe.
3. Set the cables into the groove of metal plates and screw them back to the battery packs on both sides.
4. Do remember to insert the series-connected cable at "-" and "YPLUG" on the right side of the last battery pack to complete the internal circuit.

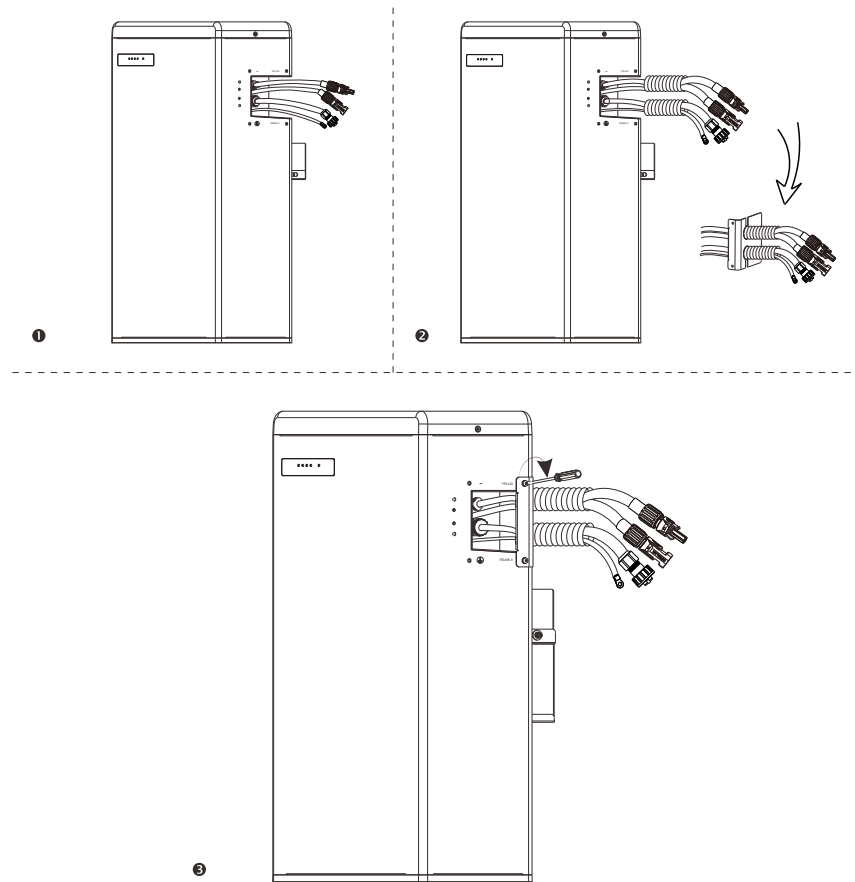

#### 4.6 Overview of Installation

The following diagram is a completed T-BAT system installation with T-BAT H 5.8/T-BAT H 5.8 V2 + three battery packs.

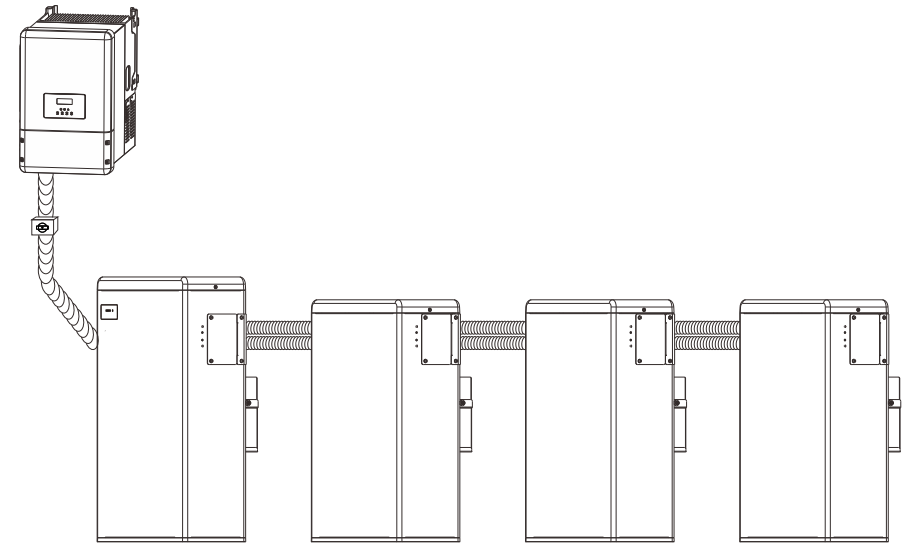

#### CAUTION!

One T-BAT system is allowed to install one T-BAT H 5.8/T-BAT H 5.8 V2 with three battery packs at most. Connecting more than three battery packs to the T-BAT system will blow the fuse, and the batteries will be damaged. Please keep in mind and follow this instruction.

## 5 Commissioning

### 5.1 Configuring Battery System

The DIP switch is used to configure the number of battery packs which are communicating to inverter. The detailed configuration information is shown as follows:

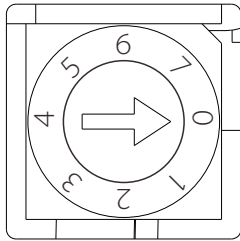

Configuration activated by inverters

- 0- Matching T-BAT H 5.8 (default) (or matching T-BAT H 5.8 V2 (default))
- 1- Matching T-BAT H 5.8 + 1\*HV11550 (or matching T-BAT H 5.8 V2 + 1\*HV11550 V2)
- 2- Matching T-BAT H 5.8 + 2\*HV11550 (or matching T-BAT H 5.8 V2 + 2\*HV11550 V2)
- 3- Matching T-BAT H 5.8 + 3\*HV11550 (or matching T-BAT H 5.8 V2 + 3\*HV11550 V2)

#### ➤ Black-start configuration

The black-start function is only used in the off-grid environment when there is no other power supply.

Note: If the battery is started in black-start mode, although there is no BMS communication, the port still has high voltage and there is a risk of electric shock!

After the black-start mode is started, if the BMS communication couldn't be built within 3 minutes, the black-start fails.

- 4- Matching T-BAT H 5.8 (or matching T-BAT H 5.8 V2)
- 5- Matching T-BAT H 5.8 + 1\*HV11550 (or matching T-BAT H 5.8 V2 + 1\*HV11550 V2)
- 6- Matching T-BAT H 5.8 + 2\*HV11550 (or matching T-BAT H 5.8 V2 + 2\*HV11550 V2)
- 7- Matching T-BAT H 5.8 + 3\*HV11550 (or matching T-BAT H 5.8 V2 + 3\*HV11550 V2)

### 5.2 Commissioning

#### 👉 NOTE!

When powering on the BMS, the system will start self-testing. If the buzzer bips, it means DIP configuration fault or communication failure occurs. If the buzzer bips, please check if the number of battery packs is corresponding to the DIP configuration, and also check if the RS485 communication cables are correctly connected. After checking above two situations, press the POWER button to power on, and press the POWER button again 10s later. In addition: The buzzer will only alarm on the corresponding fault during the power-on self-test. When the self-test is completed, it won't bip again even if the same fault occurs.

#### 👉 NOTE!

Frequently pressing the POWER button may cause system error. Please make sure at least 10 seconds is left before you pressing the POWER button the second time.



Commissioning Steps

If all the battery packs are installed, follow these steps to put it in operation.

1. Remove the upper cover board of T-BAT H 5.8/T-BAT H 5.8 V2;
2. Remove the small cover plate;
3. Rotate the DIP to corresponding number with small tool according to the number of battery pack(s) that has(have) been installed;
4. Switch the circuit breaker to ON position;
5. Press the POWER button to turn on the T-BAT system;
6. Put the small cover plate back;
7. Reinstall the upper cover board to T-BAT H 5.8/T-BAT H 5.8 V2;
8. Power on the inverter.

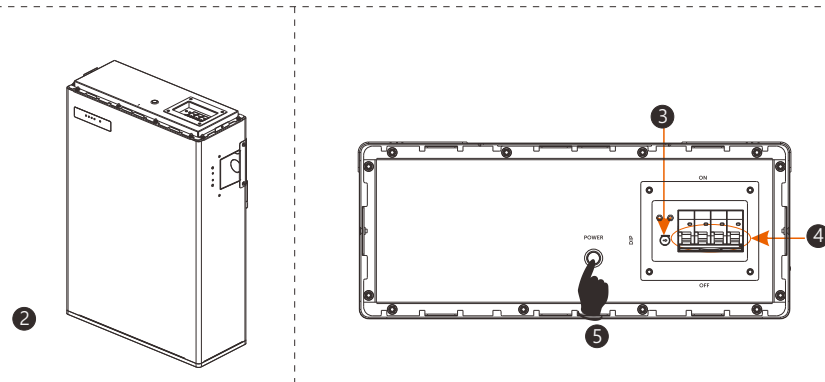
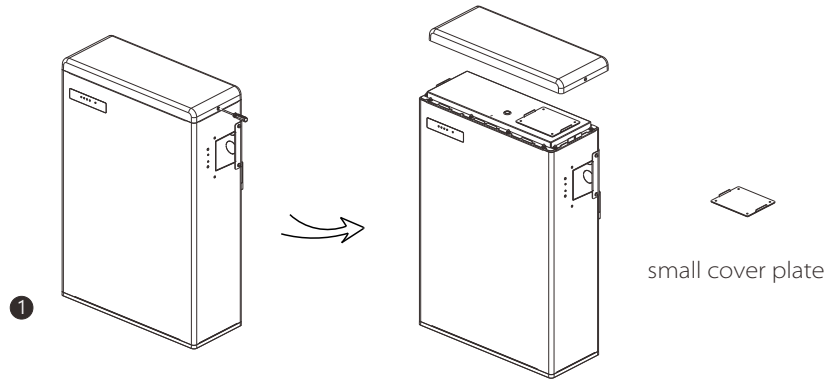

5.3 Status Indicators

The LED indicators on the front panel of the battery pack are showing the operating status.

5.3.1 BMS



The following table shows the status of BMS.

No.	Status of BMS	Mode
1	Light off	Power off
2	The Green LED is light on for 1s, and light off for 4s	Inverter sends Idle command
3	The Orange LED is light on for 1s, and light off for 4s	BMS Protection
4	The Red LED keeps lighting on for 10min, then flickers with light on for 1s, and light off for 4s	Fault
5	The Green LED is light on for 0.3s, and light off for 0.3s	Upgrade for BMS
6	The Green LED keeps light on	Active

The capacity indicators show the SOC:

- When the battery pack is neither charging nor discharging, the indicator lights are off.
- When the battery pack is charging, part of the Blue LED is flashing with the frequency of light on for 0.5s, light off for 0.5s, and part of the Blue LED keeps light on. Take SOC 60% for instance, in charging state:
  1. The first two Blue LED indicators keep on
  2. The third Blue LED indicator flashes once every 1s
- When the battery pack is discharging, the Blue LED is flashing with the frequency of light on for 1s, and light off for 4s. Take SOC 60% for instance, in discharging state:
  1. The first three blue LED indicators flash once every 5 seconds

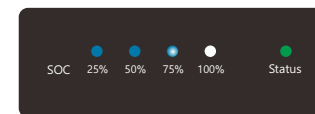

Charging

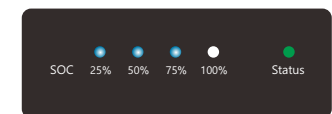

Discharging

## 5.3.2 Battery Pack



S1 and S2 represent independent status indicators. The status of S1 and S2 have the same meaning for battery pack in the following table.

Note: Only when both S1 and S2 are flashing once every 5s in Green LED, it means the battery system is active.

No.	Status of battery pack	Mode
1	Light off	Power off/Sleep
2	The Green LED is light on for 1s, and light off for 4s	Active
3	The Orange LED is light on for 1s, and light off for 4s	Protection
4	The Red LED keeps lighting on for 10min, then flickers with light on for 1s, and light off for 4s	Fault
5	The Green LED is light on for 0.3s, and light off for 0.3s	Upgrade for BMS

## NOTE!

After powering off the BMS, the LED lights of S1 and S2 will keep flashing in 20 minutes.

## 5.4 Shutting Down T-BAT System

To shut down the system, follow the steps below:

1. Turn off the breaker between inverter and battery pack;
2. Open the upper cover board;
3. Power off the BMS;
4. Turn off the system by moving the circuit breaker switch to the OFF position;
5. Make sure that every indicator on the T-BAT system is off;
6. Disconnect the cables.

## 6 Troubleshooting

## 6.1 Troubleshooting

Check the indicators on the front to determine the state of the T-BAT system. A warning state is triggered by a condition, for example, when voltage or temperature is beyond the designed limitations. The T-BAT system's BMS periodically reports its operating state to the inverter.

When the T-BAT system falls outside prescribed limits, it enters a warning state. When a warning is reported, the inverter immediately stops operation. Use the monitoring software on the inverter to identify the cause of the warning. The possible warning messages are as follows:

Warning Messages	Description	Troubleshooting
BMS_External_Err	The communication between BMS and inverter is interrupted	Check if the communication cable between BMS and inverter is correctly and well connected.
BMS_Internal_Err	1. DIP switch at the wrong position; 2. The communication between battery packs is interrupted	1. Move the DIP switch to the correct position; 2. Check if the communication cable between battery packs is correctly and well connected.
BMS_OverVoltage	Battery over voltage	Contact your distributor or our company directly for servicing.
BMS_LowerVoltage	Battery under voltage	Contact your distributor or our company directly for servicing.
BMS_ChargeOCP	Battery charge over current protection	Contact your distributor or our company directly for servicing.
BMS_DischargeOCP	Battery discharge over current protection	Contact your distributor or our company directly for servicing.

Warning Messages	Description	Troubleshooting
BMS_TemHigh	Battery over temperature	Wait till the temperature of cells go back to the normal state.
BMS_TemLow	Battery under temperature	Wait till the temperature of cells go back to the normal state.
BMS_CellImblance	The capacities of cells are different	Contact your distributor or SolaX directly for servicing.
BMS_Hardware_Protect	Battery hardware under protection	Contact your distributor or our company directly for servicing.
BMS_Insulation_Fault	Battery insulation fault	Contact your distributor or our company directly for servicing.
BMS_VoltSensor_Fault	Battery voltage sensor fault	Contact your distributor or SolaX directly for servicing.
BMS_TempSensor_Fault	Battery temperature sensor fault	Contact your distributor or our company directly for servicing.
BMS_CurrSensor_Fault	Battery current sensor fault	Contact your distributor or our company directly for servicing.
BMS_Relay_Fault	Battery relay fault	<ol style="list-style-type: none"> <li>1. Make sure the power cable is correctly and well connected to the power connector (XPLUG) of the BMS;</li> <li>2. If the first step still does not work, contact your distributor or our company directly for servicing.</li> </ol>
BMS_SelfChk_Fault	BMS selfcheck fault	Contact your distributor or our company directly for servicing.

Warning Messages	Description	Troubleshooting
BMS_CellTempDiff_Fault	The temperature between cells are different	Stop charging or discharging for a while.
BMS_CapMismatch_Fault	The capacity of battery packs are different	Contact your distributor or our company directly for servicing.
BMS_SlaveSwVer_Mismatch_Fault	The software between slavers are different	Contact your distributor or our company directly for servicing.
BMS_SlaveSw&HwMismatch_Fault	The hardware is different	Contact your distributor or our company directly for servicing.
BMS_Manu_Mismatch_Fault	The cell manufacture is different	Contact your distributor or our company directly for servicing.
BMS_MasterSw&SlaveSwMismatch_Fault	The software between Master and Slaver are different	Contact your distributor or our company directly for servicing.
BMS_ChgReqNoAck_Fault	No action for charging request	Check the information from inverter.

## 7 Decommissioning

### 7.1 Dismantling the Battery

Shutting down T-BAT system

Disconnect the cables between BMS and inverter

Disconnect the short-circuit plug on the last battery module

Disconnect the cables.

### 7.2 Packing

Please pack the BMS and battery modules with the original packaging.

If it is no longer available, you can also use an equivalent carton that meets the following requirements:

- Suitable for loads more than 70kg
- With handle
- Can be fully closed

## 8 Maintenance

-If the ambient temperature for storage is  $-20\sim 30^{\circ}\text{C}$ , recharge the batteries at least one time every 12 months.

-If the ambient temperature for storage is  $30\sim 55^{\circ}\text{C}$ , recharge the batteries at least once every 6 months.

-If the batteries have not been used for more than 9 months, these batteries must be charged to at least SOC 50 % each time.

-For the first installation, the interval among manufacture dates of battery modules shall not exceed 3 months.

-If a battery is replaced or added for capacity expansion, each battery's SOC should be consistent. The max. SOC difference should be between  $\pm 5\%$ .

-If users want to increase their battery system capacity, please ensure that the SOC of the existing system capacity is about 40%. The manufacture date of the new battery shall not exceed 6 months; in case of exceeding 6 months, please charge the new battery to around 40%.

## 9 Disclaimer

Our company protects this product under warranty when it is installed and used as listed in this manual. Violation of installation procedure or use of the product in any way not described in this manual will immediately void all warranties on the product.

In case of any following circumstance, our company does not provide warranty coverage or shall not assume any responsibility for the direct or indirect damages or defects.

- Force majeure (flooding, lightning strike, overvoltage, fire, thunderstorm, flooding etc.)
- Improper or noncompliant use
- Improper installation, commissioning, start up or operation (contrary to the guidance detailed in the installation manual supplied with each product)
- Inadequate ventilation and circulation resulting in minimized cooling and natural air flow
- Installation in a corrosive environment
- Damage during transportation
- Unauthorized repair attempts
- Failure to adequately maintain the equipment. An on-site inspection by a qualified technician is possible following 60 months of continuous use. Warranty claims made beyond 60 months from date of commissioning may be declined if it cannot be demonstrated that the equipment has been adequately maintained
- External influence including unusual physical or electrical stress (power failure surges, inrush current, etc.)
- Use of an incompatible inverter or devices
- Connect to other brands inverters without authority from our company

# Warranty Registration Form



### For Customer (Compulsory)

Name ..... Country .....

Phone Number ..... Email .....

Address .....

State ..... Zip Code .....

Product Serial Number .....

Date of Commissioning .....

Installation Company Name .....

Installer Name ..... Electrician License No. ....

### For Installer

#### Module ( If Any )

Module Brand .....

Module Size(W) .....

Number of String ..... Number of Panel Per String .....

#### Battery ( If Any )

Battery Type .....

Brand .....

Number of Battery Attached .....

Date of Delivery ..... Signature .....

Please visit our warranty website: <https://www.solaxcloud.com/#/warranty> to complete the online warranty registration or use your mobile phone to scan the QR code to register.

For more detailed warranty terms, please visit SolaX official website: [www.solaxpower.com](http://www.solaxpower.com) to check it.





PLEASE REGISTER THE WARRANTY IMMEDIATELY AFTER INSTALLATION!  
GET YOUR WARRANTY CERTIFICATE FROM SOLAX!  
KEEP YOUR INVERTER ONLINE & WIN SOLAX POINTS!

1

Open your camera app and point your device at the QR code



2

Wait for the camera to recognize the QR code



3

Click banner or notification when it appears on the screen



4

Warranty registration page will be loaded automatically

